

REINHOLD ENVIRONMENTAL Ltd.



2017 NO_x-Combustion-CCR Round Table Presentation

February 27 & 28, 2017, in Cleveland, OH / Hosted by FirstEnergy

All presentations posted on this website are copyrighted by Reinhold Environmental, Ltd (RE). Any unauthorized downloading, attempts to modify or to incorporate into other presentations, link to other websites, or obtain copies for any other uses than the training of attendees to RE's Conferences is expressly prohibited, unless approved in writing by RE or the original presenter. RE does not assume any liability for the accuracy or contents of any materials contained in this library which were presented and/or created by persons who were not employees of RE.

CSAPR Update & SCRs

Tony Licata, Consultant
Clay Erickson, Ph.D., Babcock Power
Suzette Puski, Babcock Power

2017 NOx-Combustion-CCR Round Table
Monday, February 27, 2017

CSAPR Rule Update

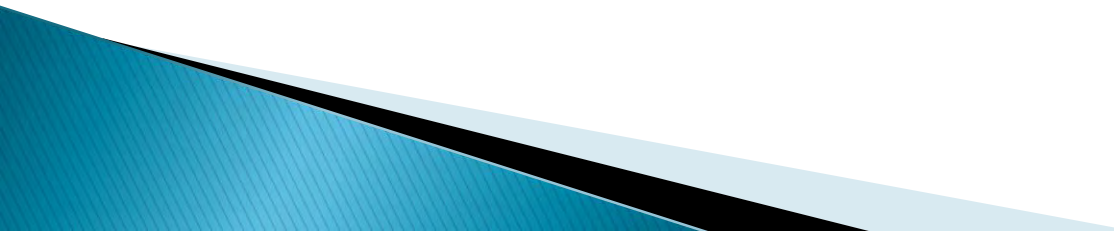
- ▶ Updated Rule Proposed Sept. 7, 2016 and published in Federal Register Oct. 24, 2016 with final rule effective on Dec. 27, 2016
 - ▶ Compliance ozone season 2017
 - ▶ No new SCRs required
 - ▶ Lower NO_x emissions required for some sites
 - ▶ Implementation cost = \$68,000,000 (annual)
- 

EPA's Compliance Cost

- ▶ For operating SCRs
 - Marginal cost to increase from partial operation to full operation reflects cost of additional reagent (does not include increased catalyst or O&M costs)
- ▶ Cost Estimates for Returning an Inactive SCR to Full Operation
 - All fixed and variable operating costs such as auxiliary fan power, catalyst, and additional administrative expenses, labor, and reagent
- ▶ Cost per unit \$241,000 per boiler??

Ballpark Cost Including Non-CAIR Units

	Plants with SCRs MW	Heat Rate used by EPA Btu/kWhr	Convert kW to MW 1,000	NOx Emissions lb/MMBtu	Convert MMBtu to Btu 1/1,000,000	Convert lb/Tons 1/2,000	Ton of NOX/hr
Current operations	143,163	10,900	1,000	0.14	0.000001	0.0005	109.23

EPA projected	143,163	10,900	1,000	0.081	0.000001	0.0005	63.20
---------------	---------	--------	-------	-------	----------	--------	-------

Nox Reduction T/hr	46.03
--------------------	-------

Hrs in ozone season	3,672
Availability	80%
Ozone NOx tons reduced	135,230

Reagent cost based on EPA's cost of \$500/t of NOx

\$ 67,614,831

EPA TOTAL cost projection

\$68,000,000

Reagent Cost 500 MW

	Plants with SCRs MW	Heat Rate used by EPA Btu/kW hr	Convert kW to MW 1,000	NOx Emissions lb/MMBtu	Convert MMBtu to Btu 1/1,000,000	Convert lb/Tons 1/2,000	Ton of NOX/hr
Current operations	500	10,900	1,000	0.14	0.000001	0.0005	0.38
EPA Projected	500	10,900	1,000	0.081	0.000001	0.0005	0.22

NOx Reduction T/hr	0.16
--------------------	------

Hrs in ozone season	3,672
Availability	80%
Ozone NOx tons reduced	472

Reagent cost based on EPA's cost of \$500/t of NOx

\$ 236,146

EPA TOTAL cost projection per boiler

\$241,000

CSAPR and Allowance Prices

- ▶ Why Allowance Prices are Important
 - Some units may not be operating at design capacity
- ▶ 2013 Allowance Market Prices
 - CAIR NO_x annual allowances averaged \$40/T
 - CAIR NO_x ozone season allowances averaged \$17/T
- ▶ Reagent cost: EPA used \$500/ton of NO_x
 - EPA used the wrong reagent cost

Allowance History

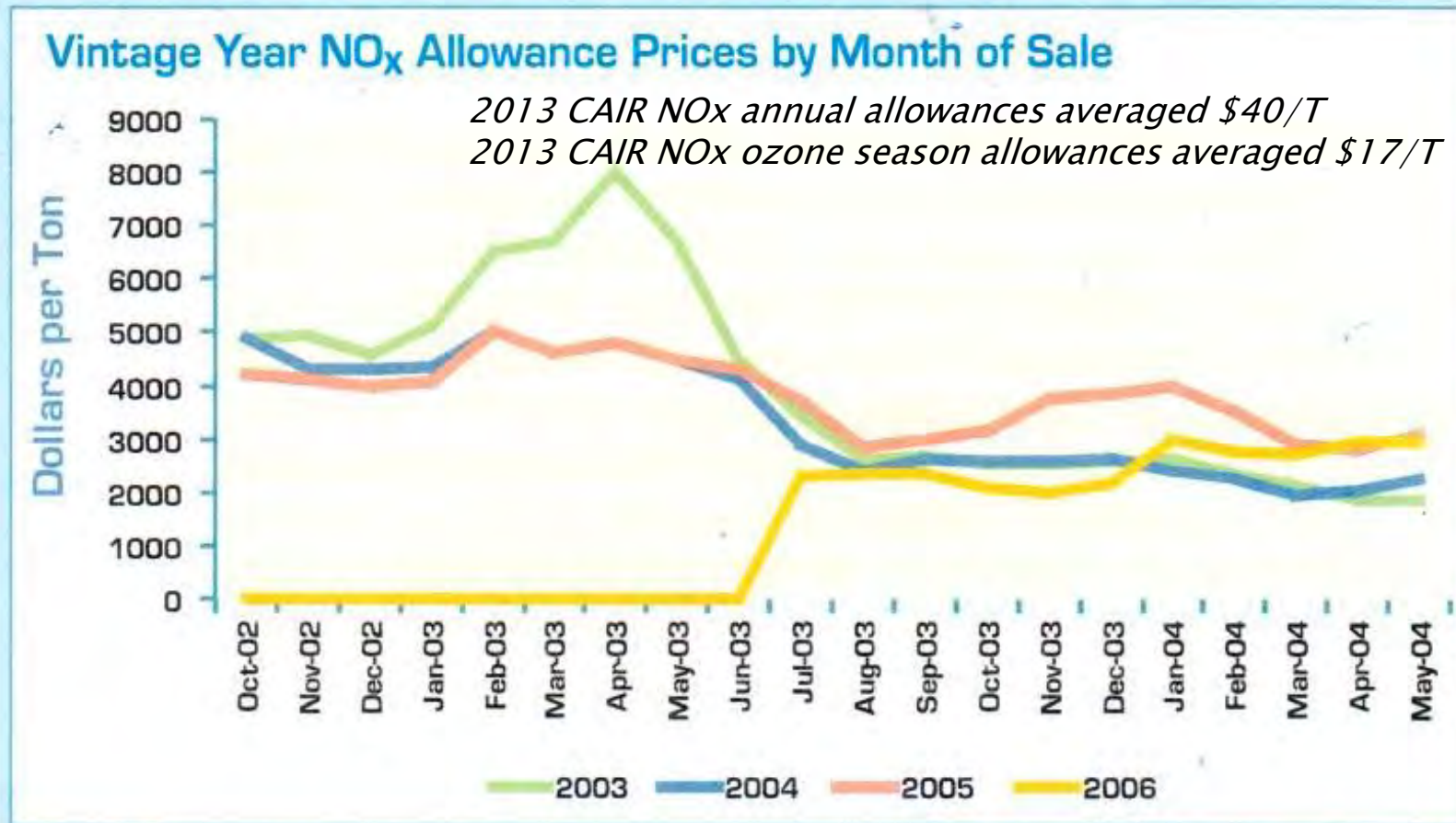



Figure 12

NBP allowance prices have fallen sharply after some early price spikes.

Source: Evolution Markets, LLC and Cantor Environmental Brokerage

EPA Control Approach: Page 1

- ▶ Fully operating existing SCRs to achieve 0.081 lb/MMBtu NO_x emission rate (costs estimated outside IPM) moving from an emission rate of 0.075 lb/MMBtu
 - ▶ Shift generation to minimize costs (costs estimated within IPM) gas, nuclear, etc.
 - ▶ Turn on idled SCRs (costs estimated within IPM)
 - ▶ Install or upgrade combustion controls (costs estimated outside IPM)
- 

EPA Control Approach: Page 2

- ▶ Upgrade existing SCR's to meet 0.081 lb/MMBtu NO_x Annual NO_x Emission Rates. In 2013 the CAIR and ARP annual NO_x emission rate was 0.14 lbs/MMBtu, a 49 percent reduction from 2005. Despite the dramatic decrease in tons of NO_x emission, heat input has remained relatively steady, indicating an improvement in emission rate. This is due in large part to greater use of control technology on coal-fired units and increased heat input at natural gas-fired units.

EPA Economics

- ▶ Fully operating existing SCRs (SCRs operating in base case): 24,100 tons \$670/ton
- ▶ Fully operating existing SCRs (SCRs not operating in base case): 4,500 tons \$1,000/ton
- ▶ Installing or upgrading NOx combustion controls: 9,700 tons \$1,200/ton
- ▶ EPA's projected reagent cost \$/ton NOx
 - In 1999 cost per ton \$108
 - In 2015 cost per ton \$500

NOx Emissions – Conflicting Databases

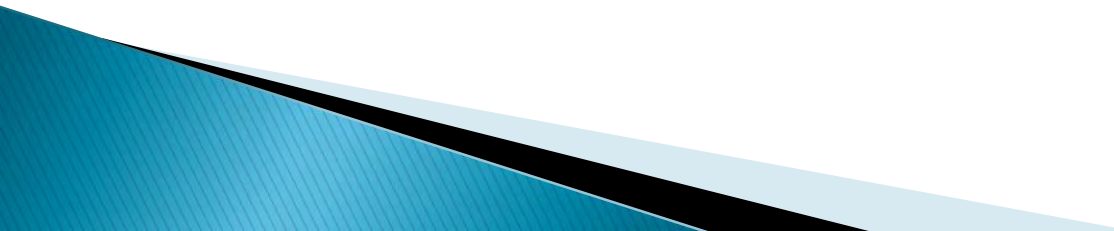
- ▶ 226 coal-fired EGUs with SCRs in EPA Clean Markets database avg. annual NOx emissions 0.13 lb/MMBtu (2015)
 - ▶ EPA's Needs 5.15 database has 282 coal-fired EGUs currently operating representing 143,163 MW approximately 50% of coal fleet.
- 

Historical Data 2005 Ozone Season

Average Hourly Ozone Season NOx Emission Rate Plus/Minus Standard Deviation

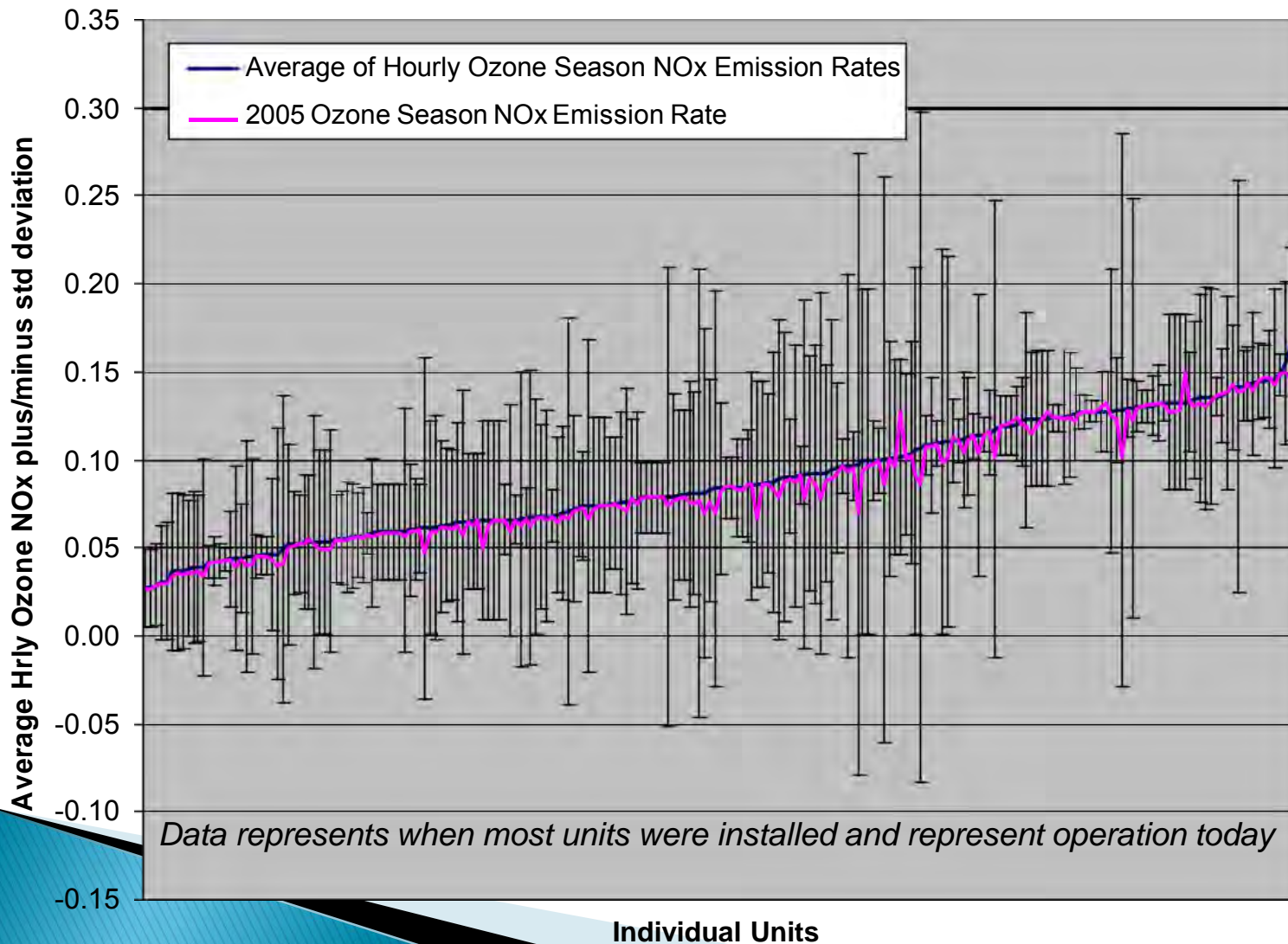

SCRs Return to Service

- ▶ Re-commissioning of idle SCRs
 - ▶ Upgrading low performing SCRS
 - ▶ Many SCRs are over 10 years old and were installed with SCR bypasses for OTAG.
 - ▶ Must consider compliance with CSAPR Update rule in conjunction with MATS and the Startup, Shutdown and Maintenance rules (SSM) also cycling loads, and extended shutdown periods and low load operations
- 

Aging Fleet of SCRs

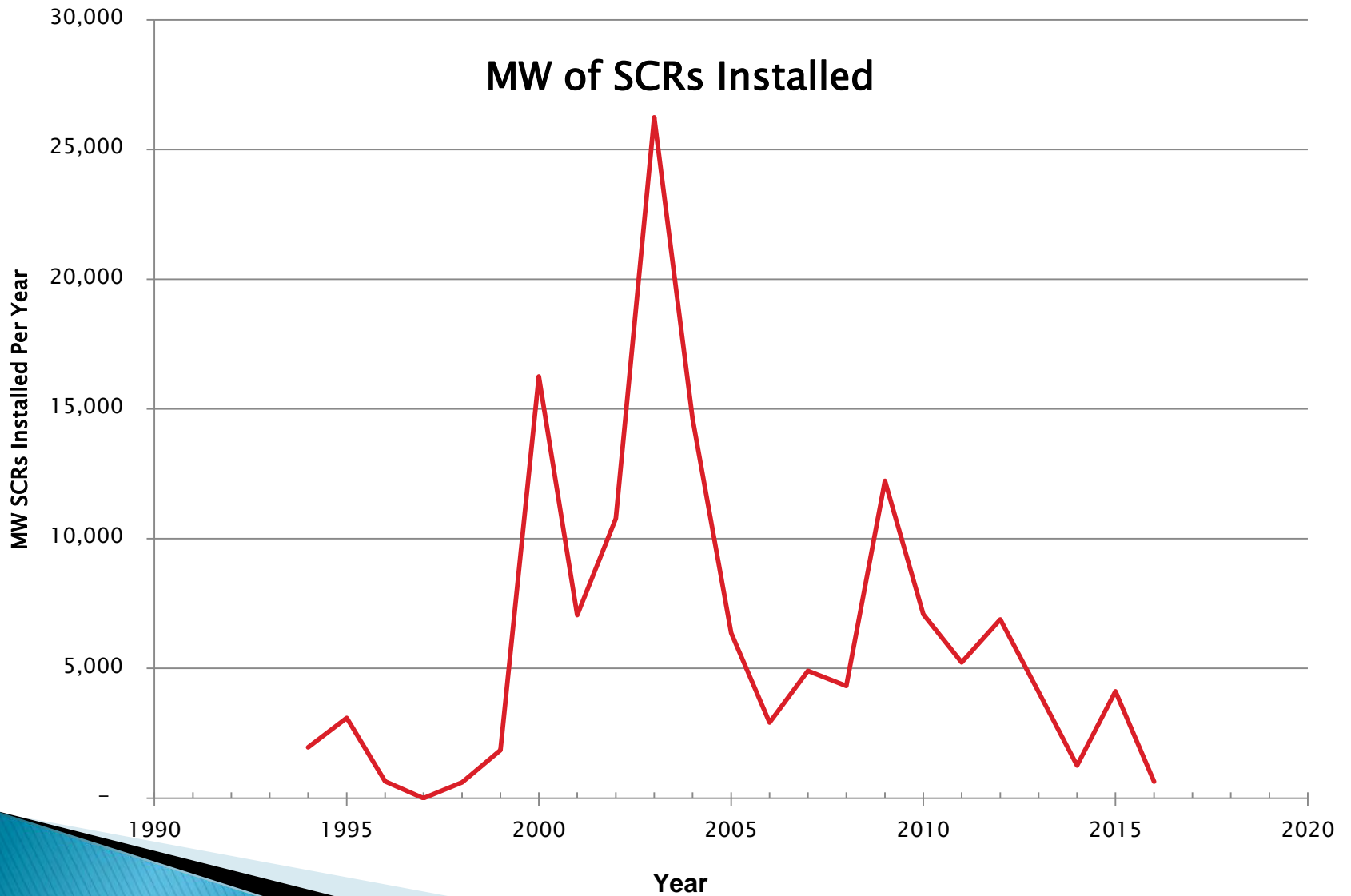

Issues Impacting SCR Performance: Page 1

- ▶ Variable load and flue gas conditions
 - Installation of economizer bypass
 - Startup/Shutdown rule
- ▶ Variable firing conditions (dual fuel configurations)
- ▶ Poor distribution
 - ABS formation in lances, catalyst and air heater
 - Ash build up in duct and on catalyst face
 - Poor temperature distribution impacts reduced load operation
 - High ammonia slip impacting marketability of fly ash

Issues Impacting SCR Performance: Page 2

- ▶ Year round SCR operation
 - More frequent catalyst change out may require quick-release large access doors (limited to number of times cut/weld panels off and on)
 - Utilize spare layer
- ▶ SCR bypass
 - Not required for startup/shutdown operation (even with oil)
 - Impacts flue gas distribution
 - Flue gas leaking through bypass causing issues with corrosion and issues with maintaining emissions limit
 - O&M associated with seal air system

Effect of Maldistribution on SCR Performance

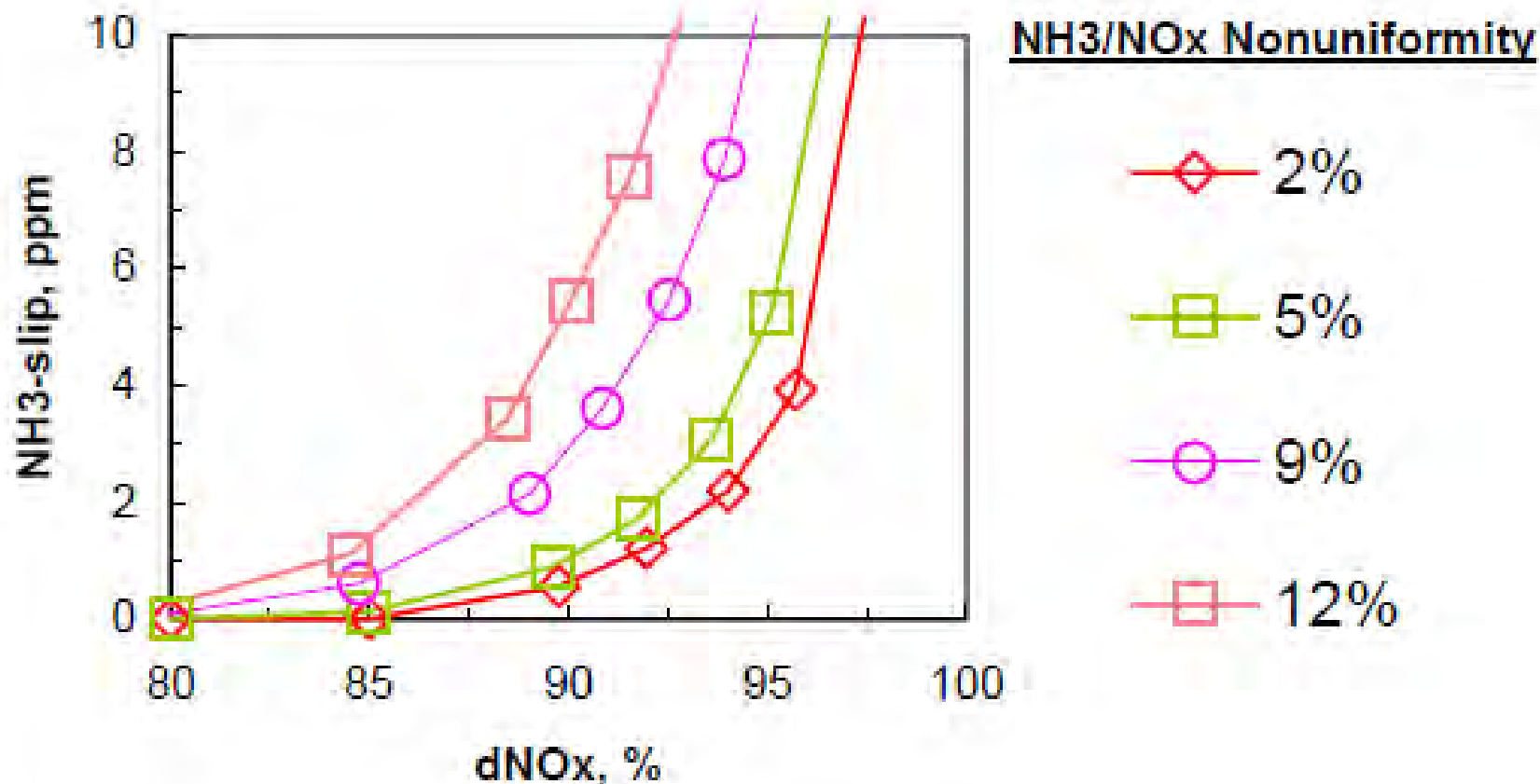

SCR & Economizer Bypass Dampers

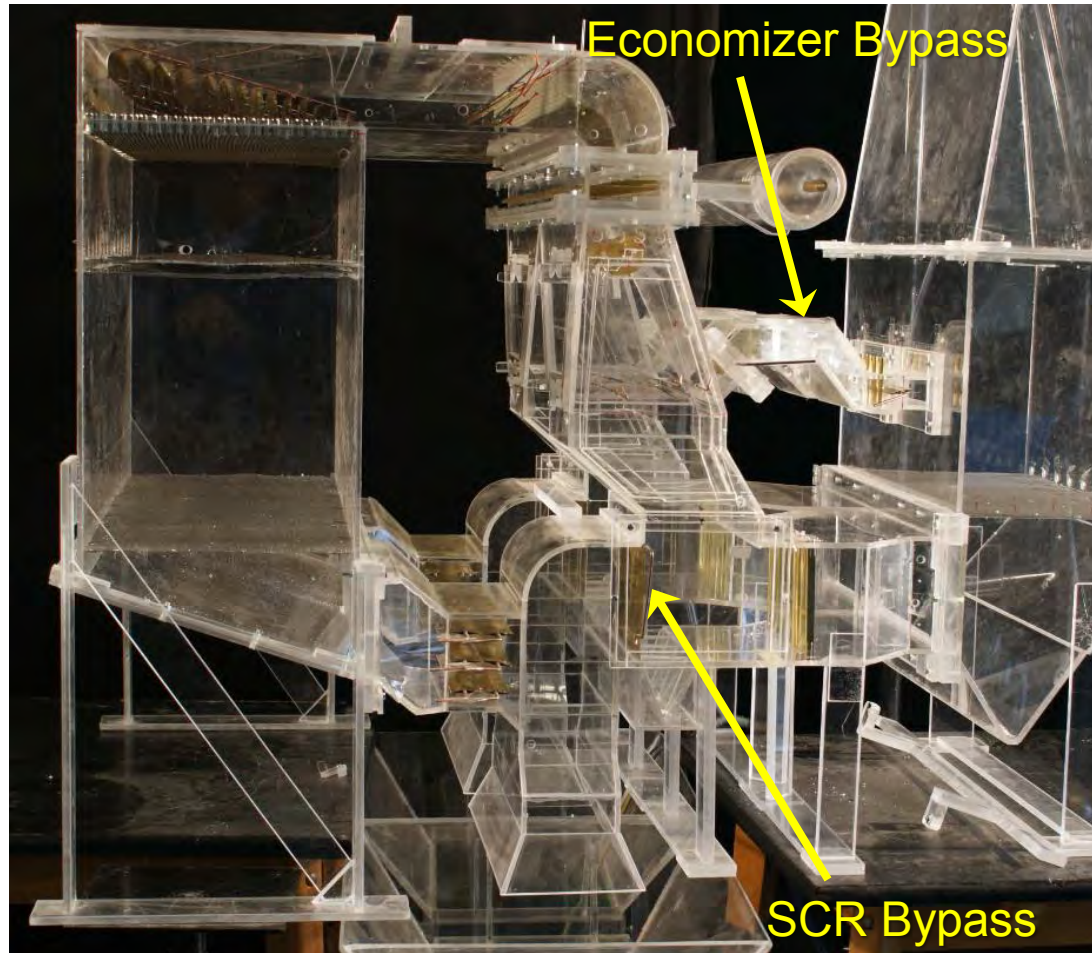

SCR Issues to Improve Performance: Page 1

- ▶ Proven Physical Modeling to improve distribution at full and reduced loads
 - Complete model to reflect actual operation
 - Improve distribution; additional mixers, turning vanes and air flow straighteners
 - Determine additional pressure drop and load on structural steel members
- ▶ Eliminate SCR bypass – Add Economizer gas or water-side bypass
 - Seal bypass & remove damper to off-balance weight added with additional mixers
 - Install screens over catalyst face; if necessary, add cleaning devices for localized buildup

SCR Issues to Improve Performance: Page 2

- ▶ Eliminate Corrosion: Structural and expansion joint leakage
 - New expansion joints and welding repairs

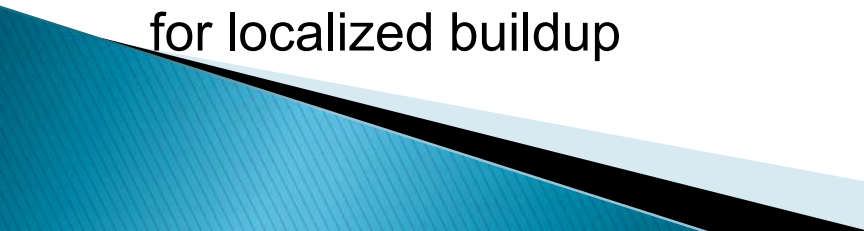
 - ▶ Improve Ash Distribution
 - CFD modeling to reduce number of high velocity zones; if necessary utilize erosion protection if high velocity areas cannot be eliminated and protect all leading edges
 - Complete dust model to maintain ash entrainment, improve distribution and minimize erosion issue on catalyst sections
 - Install screens over catalyst face and, if necessary, add cleaning devices for localized buildup
- 

SCR Issues to Improve Performance: Page 3

▶ Reagent Type/Supply

- Wide fluctuation in price related to gas prices
- Urea vs anhydrous or aqueous ammonia
- Vaporization vs direct ammonia injection

▶ LPA Screen/Issues

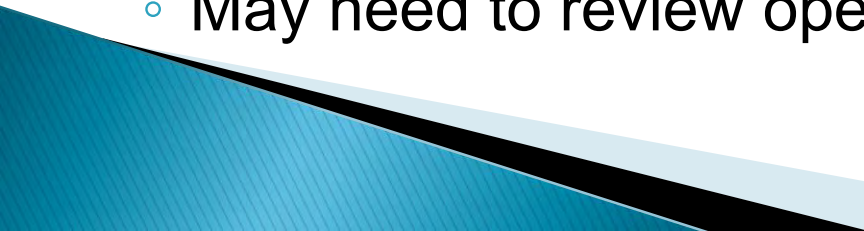
- Complete CFD modeling to reduce high velocity zones
 - Correct hopper issues with ash movement
 - May need to review operation and modify installation
- 

SCR Issues to Improve Performance: Page 4

▶ New Catalyst

- Replace catalyst or add spare layer to meet lower NO_x emissions
- Meet MATS Hg emission limits and/or minimize SO₃ formation
- Lower minimum operating temperature (coupled with improving temperature distribution)

▶ Startup bypass installed

- Meet the SSM rule and better annual NO_x rate

What an Upgrade Can Do: Page 1

▶ O&M Savings

- Reduce ammonia slip across all load
- Reduce pluggage and negative effects of ABS
- Reduce ammonia consumption and costs
- Reduce vaporizer trips and leaks
- Reduce SCR tuning requirements
- Increase catalyst life

▶ Improve Safety

- Reduce ash buildup

What an Upgrade Can Do: Page 2

▶ Optimize Performance

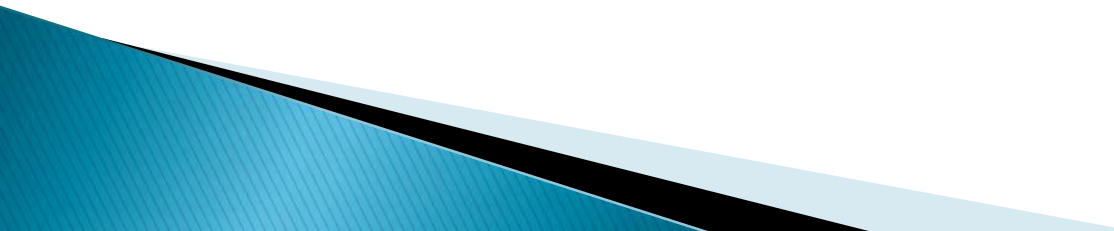
- Lower NO_x emissions due to better mixing can reduce emissions while maintaining slip
 - Increase SCR system reliability
 - Improve load following capabilities of SCR systems
 - Improve gas distribution
 - Generate additional allowances
 - Improve air heater performance/heat rate
 - Fuel flexibility
- 

What an Upgrade Can Do: Page 3

▶ Additional Benefits

- Improve dry sorbent injection performance (by improving distribution)
- Faster startup/ramping for SSM
- Increased operating time and compliance
- Improve ash sales

Flue Gas Distribution – Flow Modeling

Physical Flow Models

- Multiple, iterative runs
- Model ductwork internals (i.e., trusses)
- Model dust drop out, build-up and re-entrainment
- Model pressure drop
- Proven scale-up



CFD

- Utilized to augment the physical flow model results
- Velocity profile can be reviewed in any section
- Design LPA screen layout
- Model interrogation capabilities

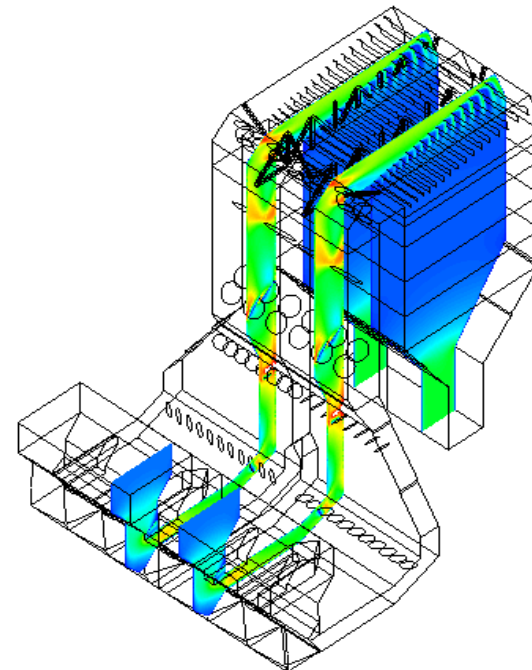

AIG Replacement with Static Mixers

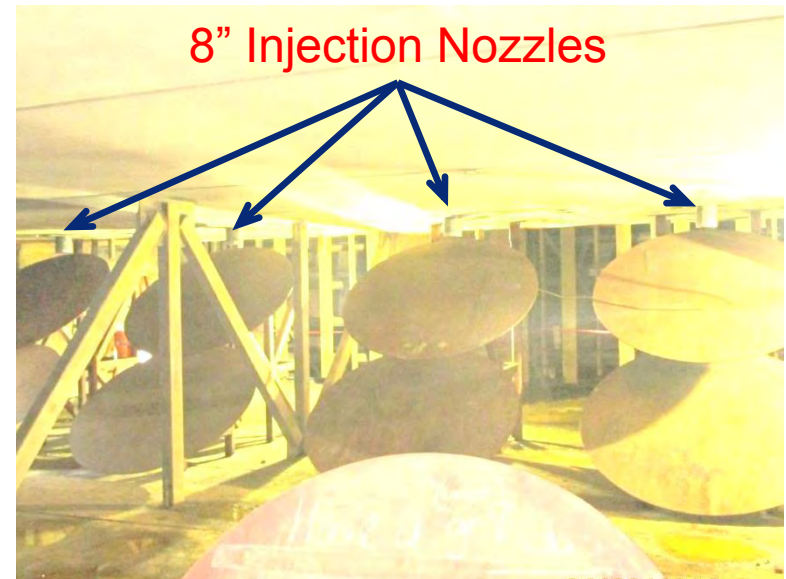

AIG Replacement with Static Mixer Results

	Unit 1	Unit 2
NOx Emissions before upgrade	0.088 lb/MMBtu	0.092 lb/MMBtu
NH ₃ /NOx, RMS%		
Before Upgrade	9.7%	7.5%
After Upgrade	3.8%	3.2%
Pressure Loss Increase	<2.0 iwc	<2.0 iwc
NOx Emissions after upgrade	0.057 lb/MMBtu	0.062 lb/MMBtu

Upgrade technology proven to address poor performance and unreliable operational issues with existing SCR systems

Mixing Consistency Throughout Load Range

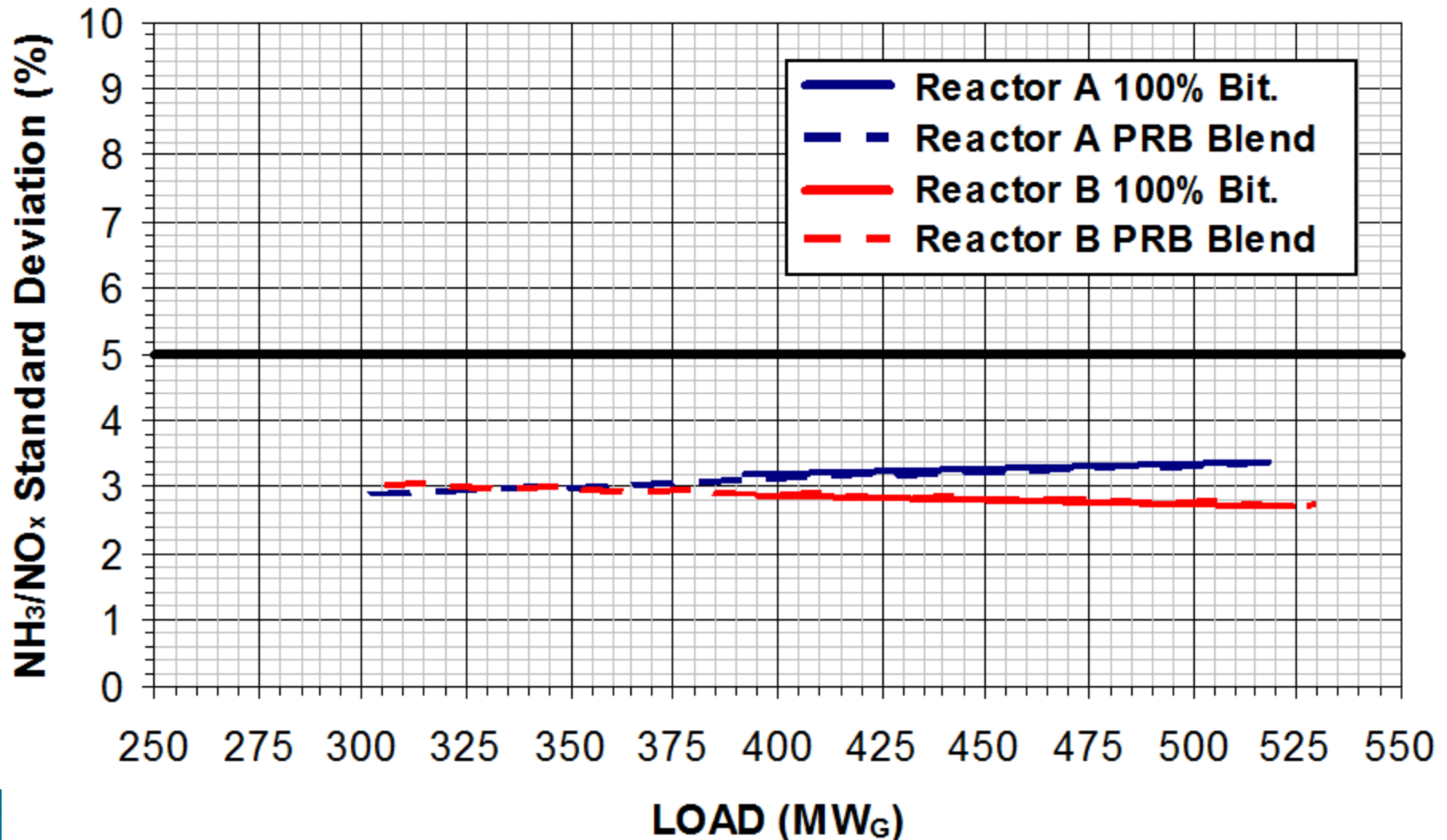

Temperature Distribution Improvement

standard deviation $\sigma_{\Delta t} = 10.7^\circ\text{F}$

max $\Delta t = +22.9^\circ\text{F}$
 -15.0°F

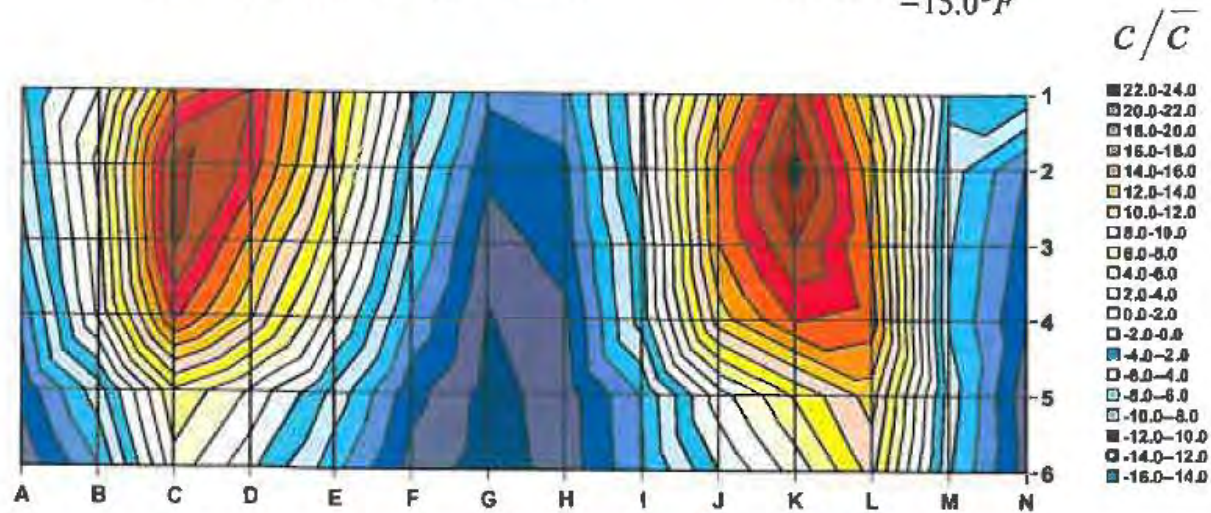

standard deviation $\sigma_{\Delta t} = 2.0^\circ\text{F}$

max $\Delta t = +3.2^\circ\text{F}$
 -4.2°F

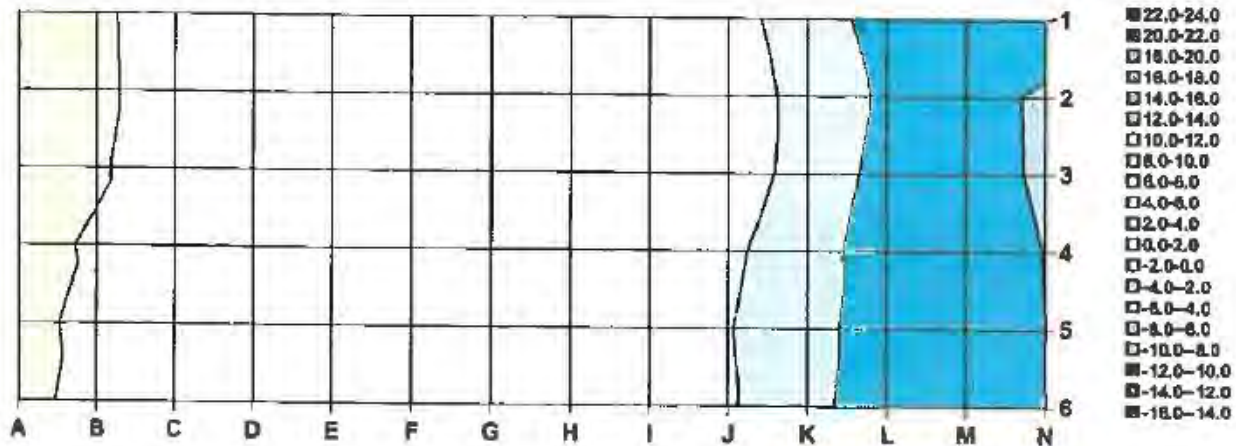

SCR Economizer Bypass Operation: Faster Startup, Load Operations, Cycling Loads

Economizer Outlet Temperature vs. Load

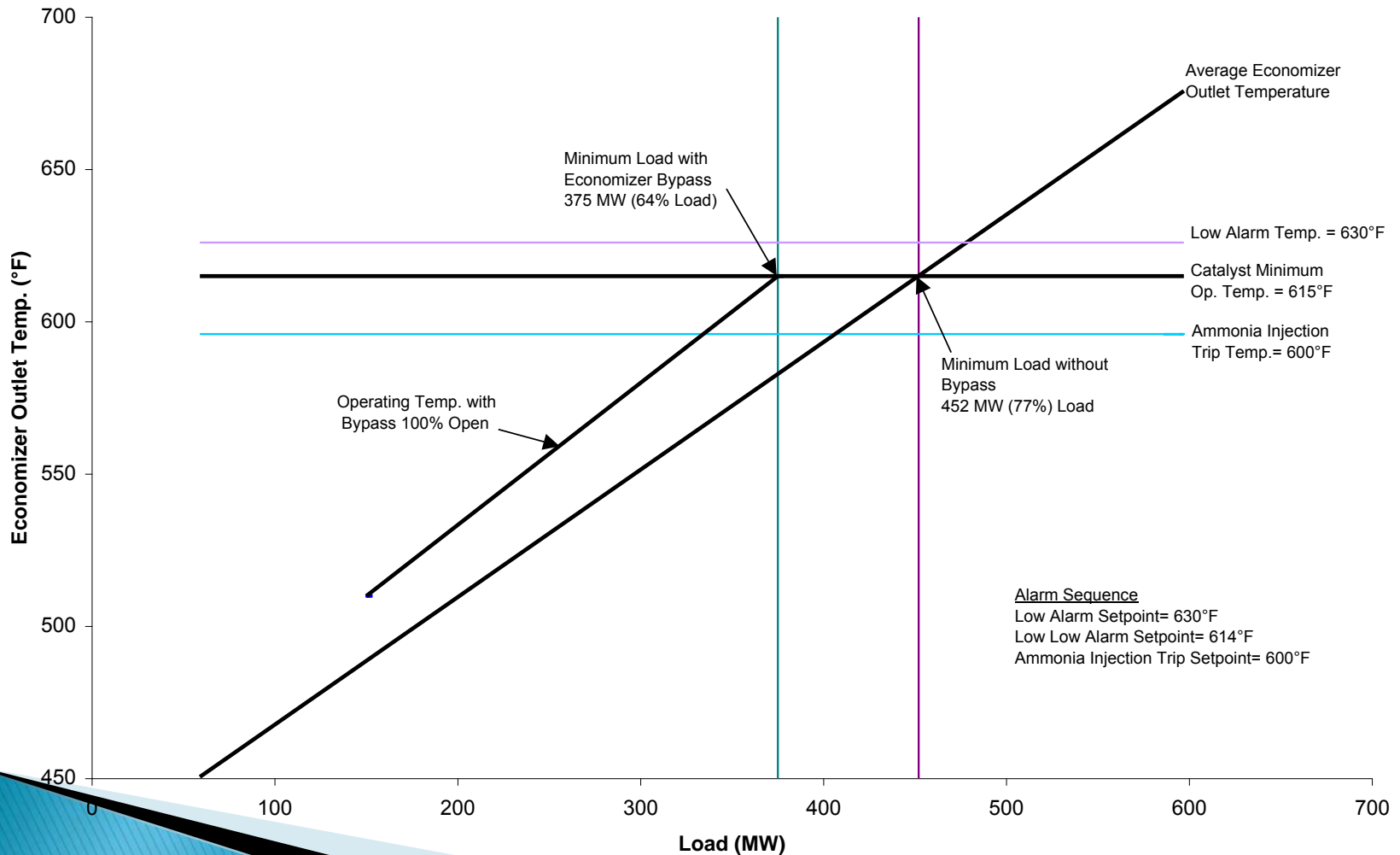

Morgantown – Min. Load 33% MCR

- ▶ Economizer exit gas temperature without bypass at minimum load: 495°F
- ▶ Flue gas temperature with economizer bypass at minimum load: 676°F
- ▶ NOx emissions:
 - Full load: 0.032 lb/MMBtu (93.6% – Guarantee 92.5%)
 - Min load: 0.048 lb/MMBtu (90.6% – Guarantee 90.0%)

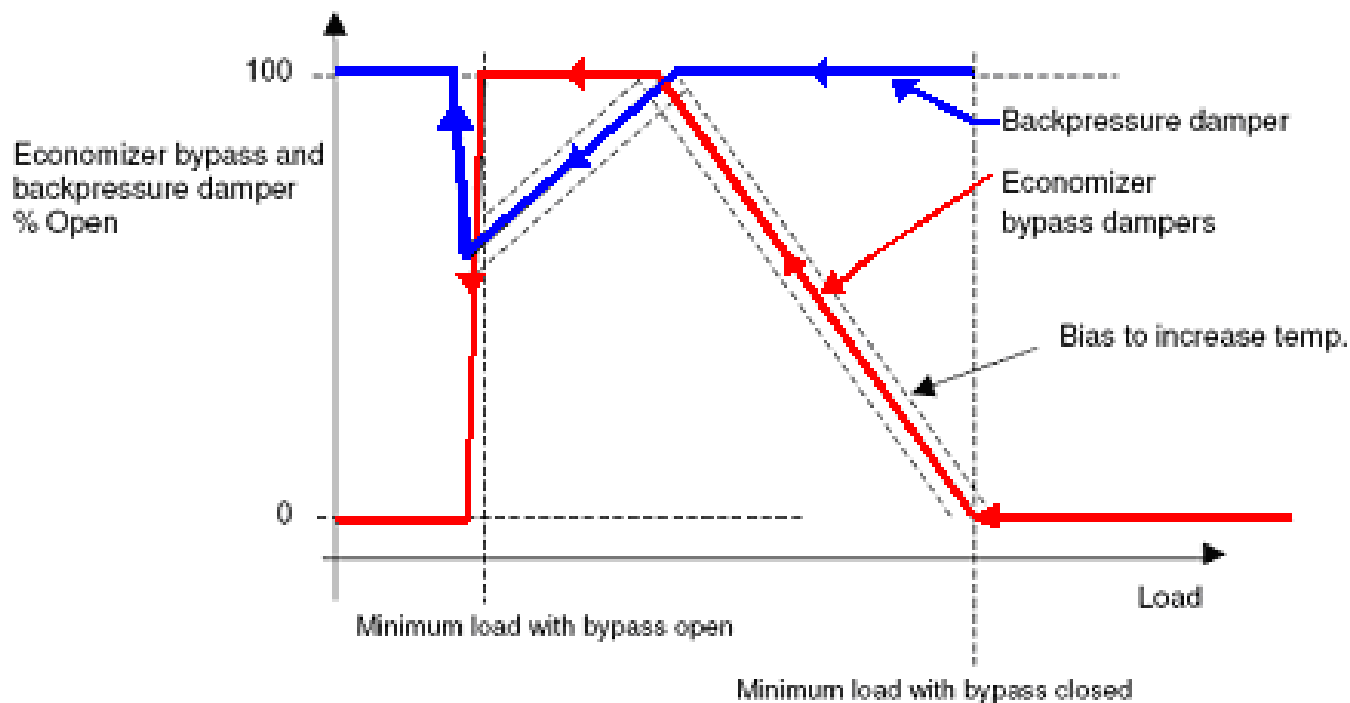

Morgantown SCR, Unit 1

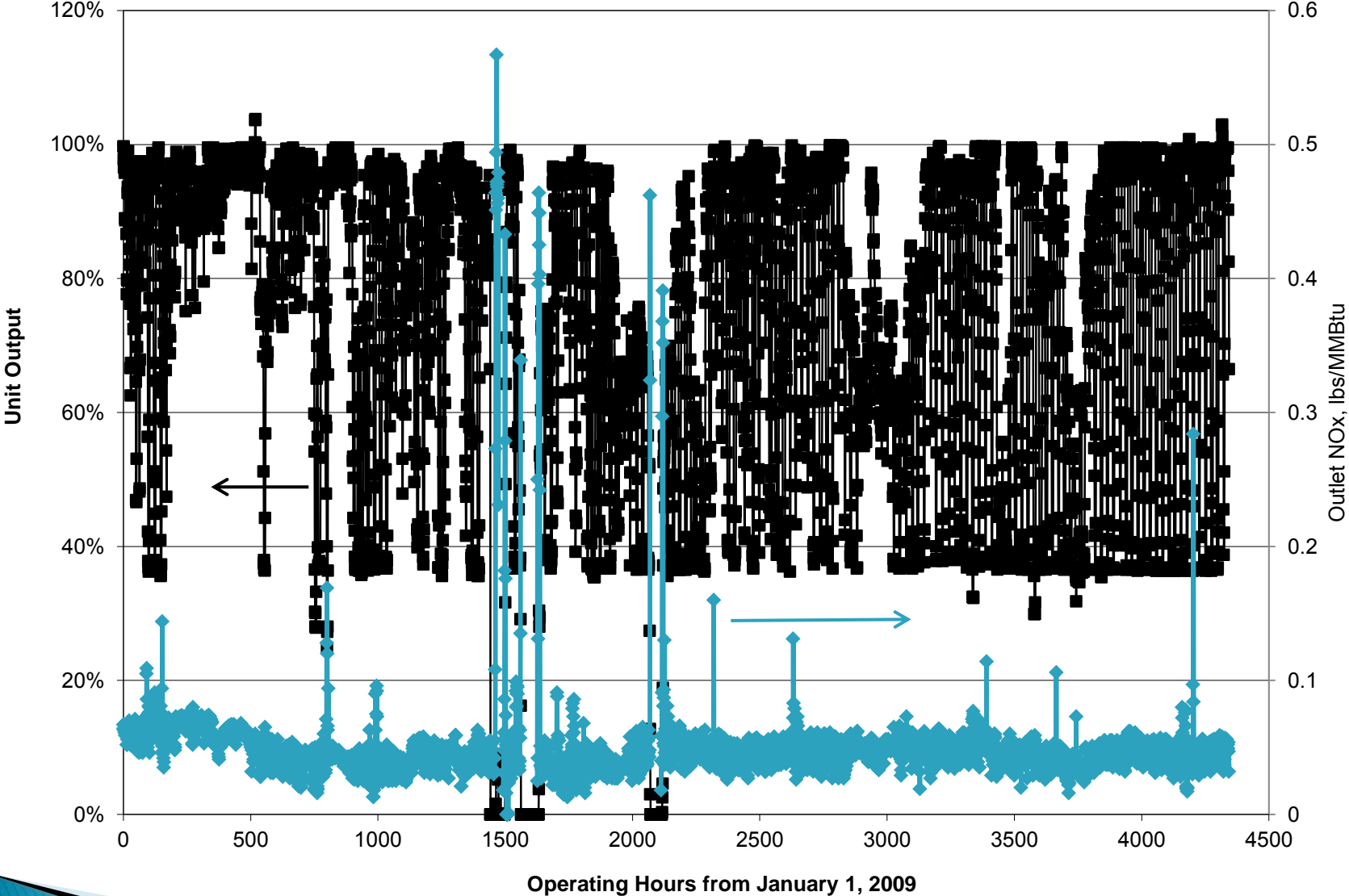

Alternative Option: Economizer Water-Side Bypass Design

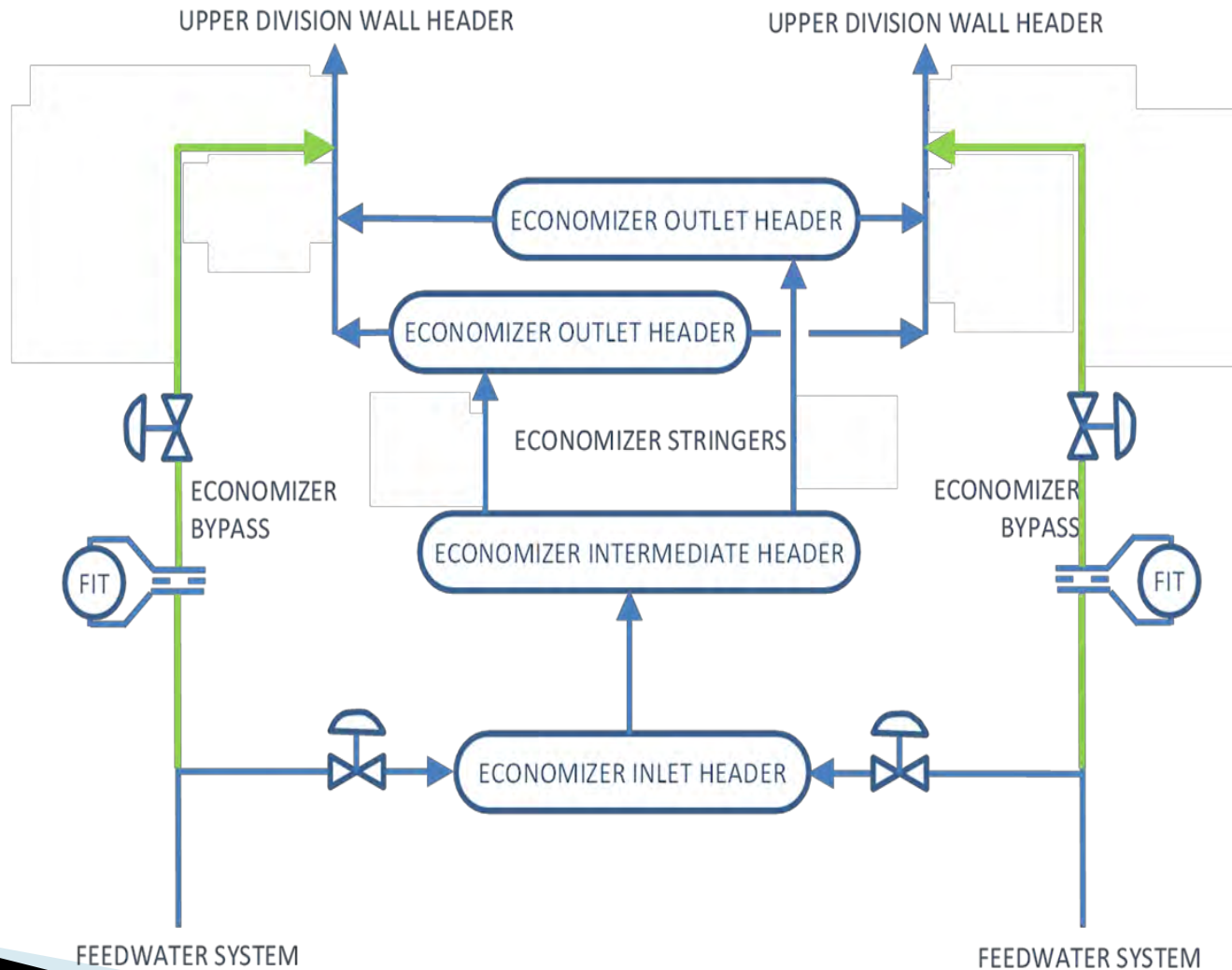

Option – Enhanced Automatic Controls

- ▶ Address a wide range of ammonia demands for dual fuel systems
- ▶ Address large NOx gradient issues on systems where upstream mixing is limited
- ▶ Utilize two control valves in series installed on each injector
- ▶ Control individual regions based on NOx concentrations
- ▶ Optimize NH₃/NOx ratio

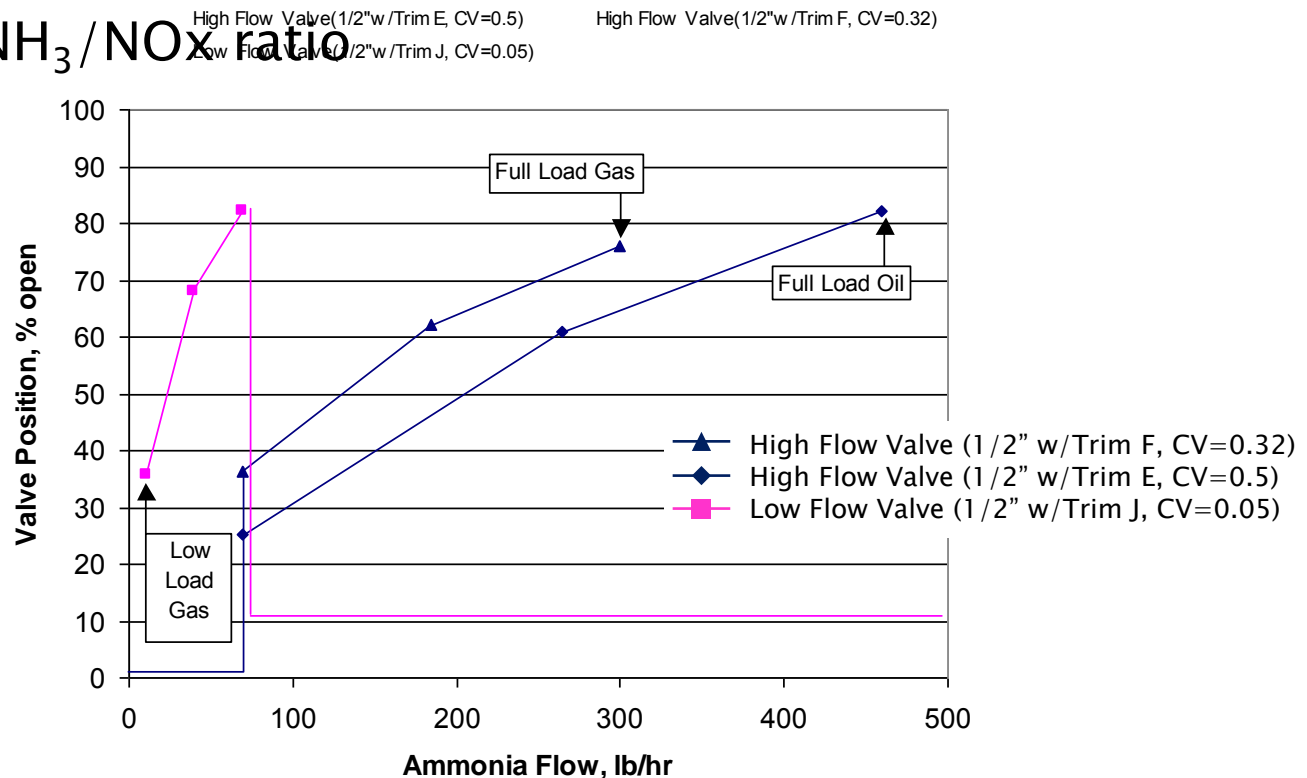

EPA Final Rule Questions

- ▶ EPA considered agricultural grade ammonia and urea in cost analysis. Should have used industrial grade at $\approx 20\%$ higher cost. See ICAC Report
- ▶ EPA may not have consider cost of outages to install combustion controls. Most plants have already installed upgraded combustion controls.
 - Some new burners will not fit in existing openings and over fire air requires new opening
- ▶ Did EPA consider the cost on intelligent controls, modeling, new AIG injection, MATS?

Summary and Conclusions

- SCR systems are a mature technology
 - Installed US fleet can benefit from upgrades based on proven technology approach of modeling and utilization of mixers
 - Reduced load operation may require modifications around the economizer section
 - Problems solvable with upgrades to current SCR technology but may exceed EPA's cost estimate
- 